

Product description
Electric
Lubrication pump
Dynamis Maxx

APPLICATION

The DYNAMIS MAXX pump was designed and developed to serve as a multi-function automatic lubricant pump. Due to its compact size and modular design, the pump can easily be modified for use in wind turbine power stations, general industry, commercial vehicle and spraying applications.

PRODUCT CHARACTERISTICS

- Pump for single-line, progressive and spray systems in wind power stations and for industrial applications
- Lubricant: grease, liquid grease up to NLGI class 2, Oil from 68 cSt
- Discharge pressure max. 160 and 300 bar
- Internal electric control (optional)
- Max. 16 outlets with flanged progressive distributor (optional)
- Filling connection
- Discharge volume: 2.9 cm³/min per pump element



ADVANTAGES

- easy installation with re-integrated distributor and control
- easy monitoring of all functions
- robust and reliable (housing made of aluminium) even when used in vertically rotating systems
- Add-on system for various applications
- high level of corrosion resistance due to powder and zinc-nickel coating
- energy-saving

DIMENSIONS (mm)

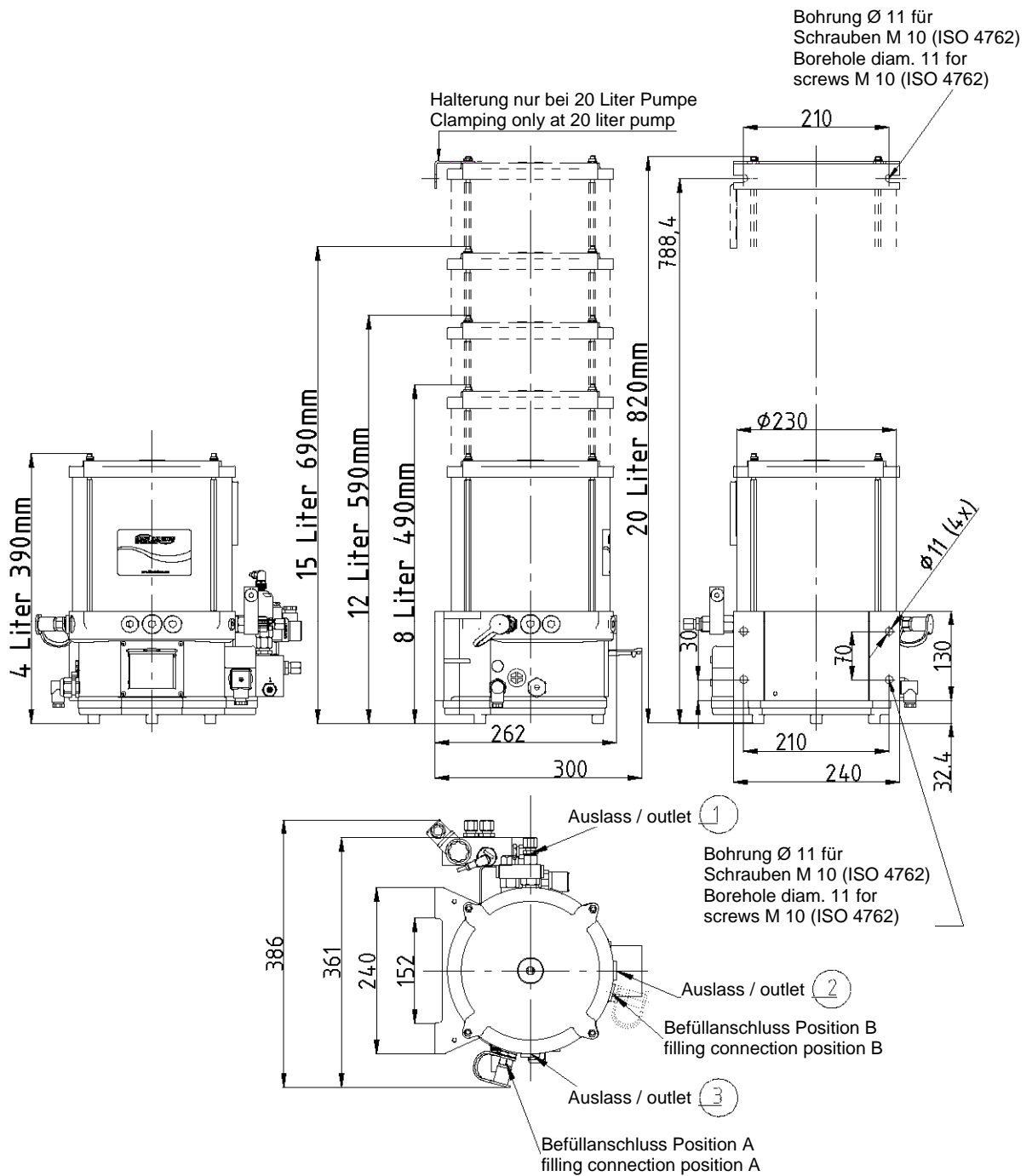

DESIGN

The unit consists of a pump housing (1), a reservoir (2), a guide rod module with spring loaded piston (3), gear motor module (4) and a drive shaft module (5). A compact electronic control module (6) is optional. A filling junction (7) is provided. Adaption of the unit for a variety of applications is accomplished by means of a connection module (8) consisting of a base plate and one or two pressure relief valves.

A proximity sensor (9), located on the top side of the housing, provides a signal to the control just prior to the follower piston reaching its low end position; (minimum filling level). By varying the modules, the pump may be utilized with internal or external progressive distributor(s), single-line injectors with electric reversing, or in spray lubrication applications.

Many combinations are possible through mix and match utilization of various functional plates, pump elements and pressure relief valves; making this an extensively flexible modular system.

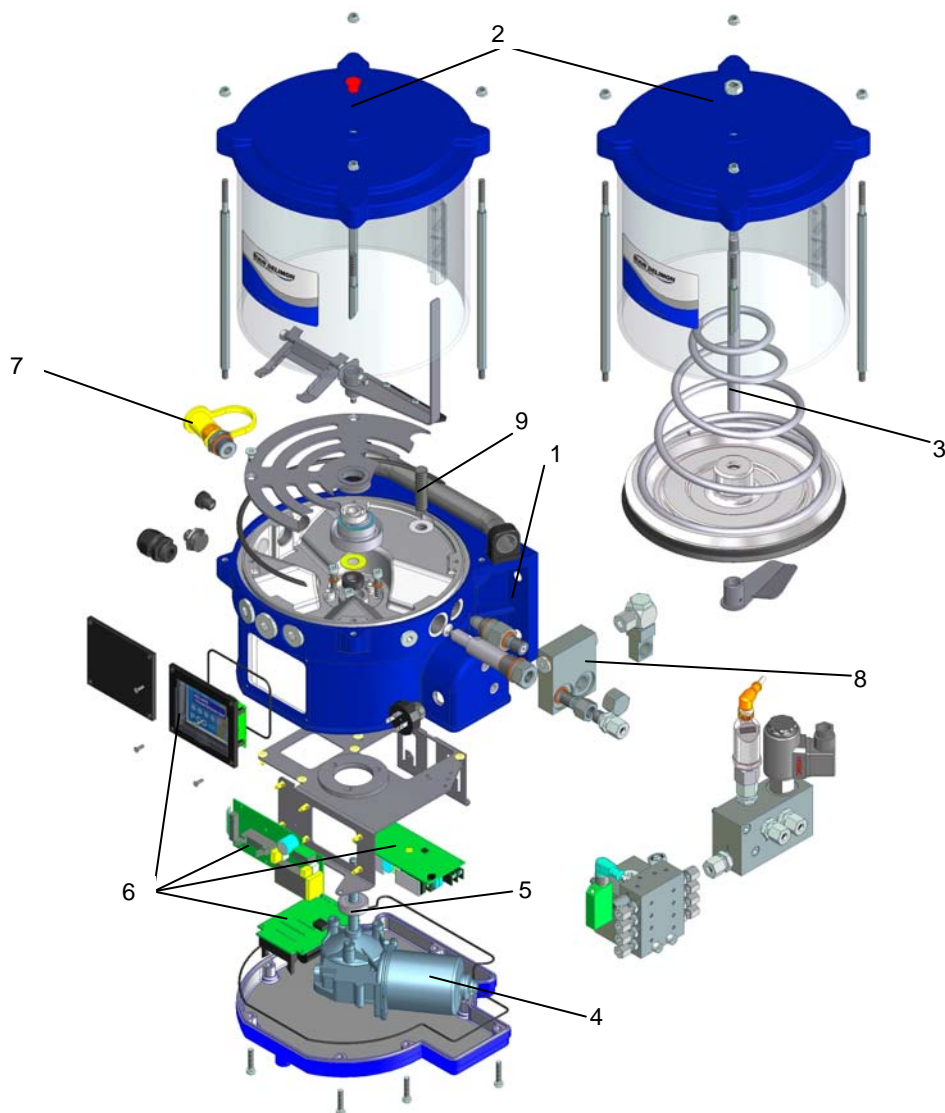

Fig 1 (Pump design)

SYSTEM VERSIONS AND EXAMPLES

Pump version with free outlet

In this version the lubricating points are supplied from one, two or three pump elements. The pump elements can also be combined to one outlet. The pump elements can be equipped individually with one pressure-relief valve each or when combined together with just one common pressure-relief valve. The maximum pressure can be set to 160 or 300 bar. The pump version with a free outlet (outlets) can be used e.g. for spraying lubrication or when externally positioned progressive distributors are used.

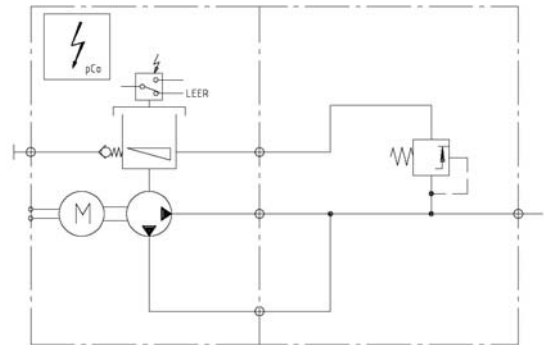

Fig. 2 (pump version with free outlet)

However, it is also possible to arrange for the individual discharge volumes to be delivered separately and to use separate pressure relief valves for setting maximum pressures.

The free outlet pump version quite suitable for use with externally mounted progressive distributors or in a variety of spraying applications.

Pump version for progressive systems (integrated progressive distributor)

In the pump variant with an integrated progressive distributor the volumes fed from one, two or three pump elements are brought together into the functional plate and protected by means of a common pressure-relief valve. All familiar versions of the PVB progressive distributor can be used. The proper functioning of the progressive distributor is monitored by means of a proximity sensor. These signals can be processed by the pump control. It is possible to use angular connection screw joints with a non-return valve.

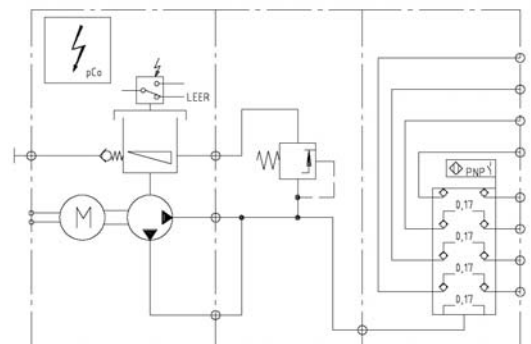

Fig. 3 (pump version with progressive distributor integrated in the connection module)

Progressive distributor function is monitored through use of a proximity sensor (22). Signals generated are also processed by the controller. When necessary, it is possible to use angular connection screw joints with a non-return valve.

SYSTEM VERSIONS AND EXAMPLES (continued)

Pump version for progressive systems (externally located progressive distributor)

In the pump variant for externally located progressive distributors, one, two or three pump elements can be connected individually or combined (for larger quantities of lubricant) to up to two external lubricant distributors. A pressure-relief valve (item 23, 160 bar and 300 bar maximum pressure) can be located in each pump element. If the set pressure is exceeded, the pressure relief valve opens and the lubricant is diverted directly back into the pump chamber.

The monitoring signal from one or two external distributors can be evaluated in the pump control in the Dynamis Maxx.



23

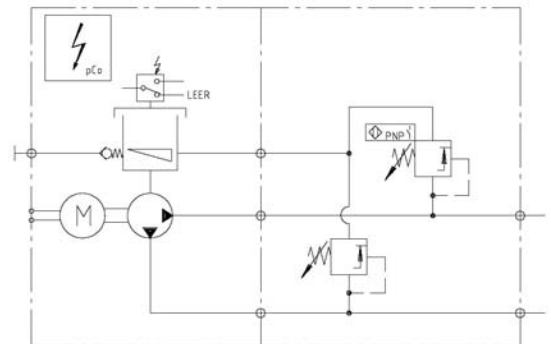
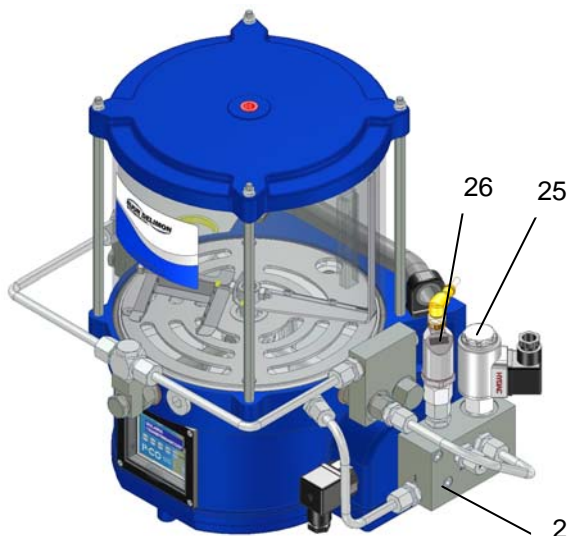

Fig. 4 (Pump version with externally connectable progressive distributors)

Pump design for single line systems

In the pump variant for single-line systems, one, two or three pump elements are brought together and protected by means of a pressure-relief valve (maximum pressure 160 or 300 bar). The lubricant is then conveyed into a functional plate (24), into which a 3/2-way solenoid valve (25) and a pressure switch (26) are screwed in. The pressure switch (26) has two separately set switching points for controlling the process. The main lubricant feeding line to a downstream single-line distributor is switched over to pressure relief by the 3/2-way solenoid valve. A further pressure relief valve (27) is screwed into the return line in the functional plate and this maintains a residual pressure and accordingly prevents the main line emptying.



24, 27

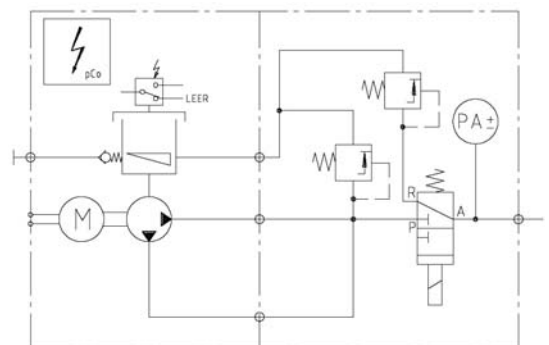
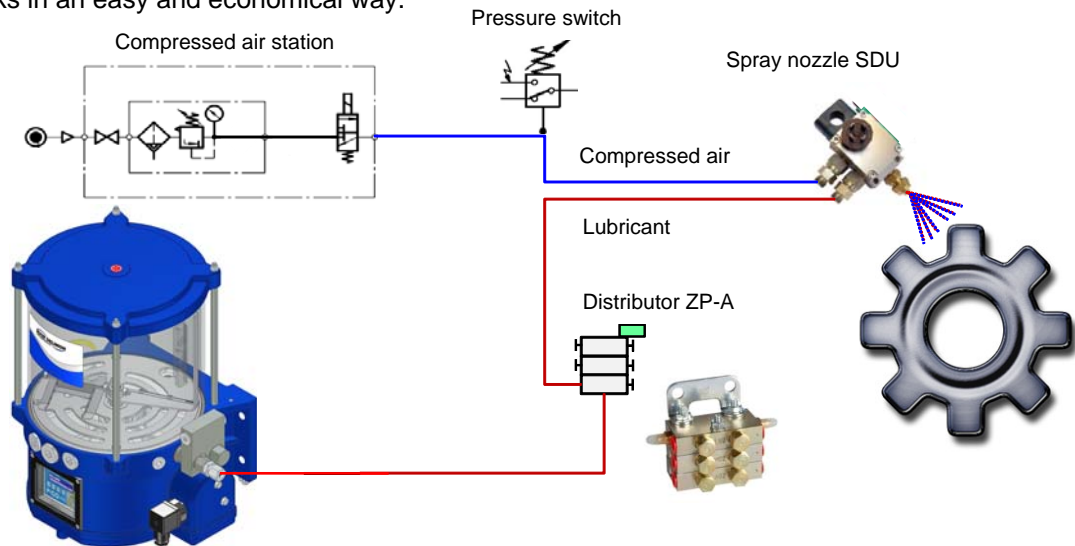

Fig 5 (Version for single-line system with electric reversing gear)

SYSTEM VERSIONS AND EXAMPLES (continued)

Example of an application use with the SDU spray nozzle

In the system version of free outlet with an external progressive distributor (progressive system), another possible application is a combination with the SDU spray nozzle. The compact construction of the Dynamis Maxx lubricant pump makes it possible to spray onto the lubricating pinions' drive pinions and tooth flanks in an easy and economical way.



A. PUMP TYPE	Code
	DYX
B. LUBRICATION SYSTEM	Code
Multi-line / version with free outlet (outlets)	ML
Version for single line system	*
Version for progressive system	*
Version for spray lubrication system	*
Version for air-oil system	*
* is determined by system selection of the price list	
C. REVISION	Code
Status A	A
D. VERSION OF PUMP ELEMENT 1	Code
without pump element	0
with pump element, without relief valve	1
with pump element, with relief valve 160 bar	2
with pump element, with relief valve 300 bar	3
with pump element, without relief valve; connected with other pump elements	4
with pump element, with relief valve 160 bar; connected with other pump elements	5
with pump element, with relief valve 300 bar; connected with other pump elements	6

E. VERSION OF PUMP ELEMENT 2	Code
without pump element	0
with pump element, without relief valve	1
with pump element, with relief valve 160 bar	2
with pump element, with relief valve 300 bar	3
with pump element, without relief valve; connected with pump element 1	4
with pump element, without relief valve; connected with pump element 1 + 3	5

F. VERSION OF PUMP ELEMENT 3	Code
without pump element	0
with pump element, without relief valve	1
with pump element, with relief valve 160 bar	2
with pump element, with relief valve 300 bar	3
with pump element, without relief valve; connected with pump element 1	4
with pump element, without relief valve; connected with pump element 2	5

G. RESERVOIR SIZE	Code
4 liter with follower plate; without level control	A
8 liter with follower plate; without level control	B
12 liter with follower plate; without level control	C
15 liter with follower plate; without level control	D
20 liter with follower plate; without level control	E
4 liter with follower plate; with level control EMPTY	F
8 liter with follower plate; with level control EMPTY	G
12 liter with follower plate; with level control EMPTY	H
15 liter with follower plate; with level control EMPTY	I
20 liter with follower plate; with level control EMPTY	J
4 liter without follower plate; without level control	K
8 liter without follower plate; without level control	L
12 liter without follower plate; without level control	M
15 liter without follower plate; without level control	N
20 liter without follower plate; without level control	O
4 liter without follower plate; with level control EMPTY	P
8 liter without follower plate; with level control EMPTY	Q
12 liter without follower plate; with level control EMPTY	R
15 liter without follower plate; with level control EMPTY	S
20 liter without follower plate; with level control EMPTY	T

H. OPERATING VOLTAGE	Code
12 V DC	1
24 V DC	2
115 V AC, $\pm 15\%$ / 50 - 60 Hz	3
230 V AC, $\pm 15\%$ / 50 - 60 Hz	4

I. CONTROLLER / INTERFACE	Code
internal controller, 1 x plug DIN 43650, 3-pole	01
internal controller, 1 x plug DIN 43650, 3-pole + 1 x plug M 12x1, 8-pole	02
internal controller, 1 x plug DIN 43650, 3-pole + cable gland M 20x1.5	03
internal controller, 1 x plug DIN 43650, 3-pole + 1 x plug M 12x1, 8-pole + cable gland M 20x1,5	04
Advice: Plug DIN 43650, 3-pole – for power supply Plug M12x1, 8-pole - for status signals Cable gland M 20x1.5 for connection of sensors/pressure switches within the pump	
without controller, 1 x plug DIN43650, 3-pole	11
without controller, 1 x plug DIN43650, 3-pole + 1x plug M12x1, 4-pole	12
without controller, 1 x plug DIN 43650, 3-pole + 1x plug M12x1, 4-pole + cable gland M 20x1.5	13
without controller, 1 x plug DIN 43650, 3-pole + 1x plug M12x1, 8-pole + cable gland M 20x1.5	14
without controller, 1 x plug DIN43650, 3-pole + 1x plug DIN 43650, 4-pole	19
Advice: Plug DIN 43650, 3-pole - to connect the motor Plug DIN 43650, 4-pole - for level switch Plug M12x1, 4-pole - for up to 2 switching signals (e.g. level switch) Plug M12x1, 8-pole - for up to 5 switching signals (e.g. level switch) Cable gland M 20x1.5 for connection of sensors/valves within the pump	

J. ACCESSORIES	Code
without	00
1x cable connector DIN43650, 3-pole	06
1x cable connector DIN43650, 3-pole + 1x cable connector M12x1, 8-pole	07
1x cable connector DIN43650, 3-pole + 1x cable connector M12x1, 4-pole	08
2x cable connector DIN43650, 4-pole	09

RECOMMENDED ACCESSORIES (must be ordered separately)

1. Connection to voltage supply Suitable cable: PVC NYSLYÖ-J 3 x 1 mm ²	769212643
2. Connection of signals Suitable cable: UNITRONIC® PUR CP control line 7x0.25 mm ²	769217027
If the pump is ordered without internal control, the attached electrical devices (valves, pressure switch, monitoring switches) must be wired by the user. The factory offers the valves as standard with line sockets without any protection circuit. At 230 V AC supply voltage, the standard line sockets can be used without a protection circuit; for 24V DC supply voltage we offer you the following line sockets <u>with</u> protection circuit:	
3. Connection for valves	
a. Line socket DIN 43650 with protection circuit and status LED	769289233
b. Suitable cable: PVC NYSLYÖ-J 3 x 1 mm ²	769212643
4. Connection of pressure switch for a single-line system	
a. Line socket 4-pole, angular, M 12x1 with 2 m cable	76928E042
5. Connection of monitoring switch 669251311 (relief valve)	
a. Selection as per data sheet 669251311	
6. Counterpart of the filling connection	734142583

SPECIFICATION

General details

Operating pressure max. 160 and 300 bar
 Motor voltage : 12 / 24 V DC or 115 / 230 V AC
 Motor power : 50 W
 Lubrication outlet : G 1/4
 Rated single-piston delivery rate (also in combination): 2.9 cm³/min
 Temperature range: - 30° to + 75° C
 Acceptable lubricants : NLGI 000 class 2
 (if operated at low temperature, select low temperature lubricant)
 Available reservoir capacities : 4 l, 8 l, 12 l, 15 l or 20 l
 Discharge element output port (optional): Quick connector Rc1/4
 Protection system : IP67

Notes:

- Lubricants should be selected according to specific operating temperatures.
 Contact BIJUR DELIMON should you require additional assistance.
- Electrical specification
 Number of connections : 3 + PE
 Specification of power cable : AWG20 -14
 Diameter of power cable : 6 – 9,5 mm
 Protection system : IP67

EXAMPLE OF ORDER

		Code									
		DYX	ML	A	2	0	0	G	2	02	00
Pump type DYNAMIS Maxx	Code: DYX										
Lubrication system											
Multi-line / version with free outlet (outlets)	Code: ML										
Revision											
Status A	Code: A										
Version of pump element 1											
with pump element, with relief valve 160 bar	Code: 2										
Version of pump element 2											
without pump element	Code: 0										
Version of pump element 3											
without pump element	Code: 0										
Reservoir size											
8.0 liter, with follower plate, with level control EMPTY	Code: G										
Operating voltage											
24V DC	Code: 2										
Controller / Interface											
internal controller, 1 x plug DIN 43650, 3-pole + 1 x plug M 12x1, 8-pole	Code: 02										
Accessories											
without	Code: 00										

DELIMON
Zentrale
Arminstraße 15
D-40227 Düsseldorf
Telefon: +49 211 7774 0
Telefax: +49 211 7774 210
kontakt@bijurdelimon.com
www.bijurdelimon.com

DELIMON
Niederlassung Beierfeld
Am Bockwald 4
D-08344 Grünhain-Beierfeld

DELIMON
Österreich
Lemböckgasse 49
Haus 2 / Stiege E 4.OG / Top E 4-3
A-1230 Wien
Telefon: +43 1 585 66 17
Telefax: +43 1 585 66 17 50
kontakt@bijurdelimon.com
www.bijurdelimon.com

LUBRIMONSA
Spain
Avda. Txori-Erri 38
48150 Sondica - (Vizcaya)
Teléfono: +34 94 453 20 00
Fax: +34 94 453 25 00
spain@bijurdelimon.com

DENCO Lubrication Ltd.
DELIMON-Cooling
United Kingdom
Ramsden Court, Ramsden Road
Rotherwas Industrial Estate
Hereford, HR2 6LR
Phone: +44 (0) 1432 365 000
Fax: +44 (0) 1432 365 001
info@delimon.co.uk
www.bijurdelimon.com

BIJUR Products, Inc.
France
P.O. Box 50
Z.I. de Courtabœuf
9, Avenue du Québec
91942 Courtabœuf Cedex
Tél.: +33 1 692 985 85
Fax: +33 1 690 776 27
contact@bijurdelimon.com
www.bijurdelimon.com

BIJUR Lubricating Ireland Ltd.
Gort Road
Ennis, County Clare
Tel.: +35 3 65 682 1543
Fax: +35 3 65 682 0327
www.bijurdelimon.com

*Für reibungslöse Bewegung
For smooth motion*